



Standard Equipment/Optional Equipment

Standard Equipment

Linde twin drive pedals to control forward/reverse travel and braking
 Linde Load Control integrated in armrest
 Container entry height (overhead guard 2123 mm)
 Hydraulic suspended comfort-class seat with extensive range of adjustment
 Hydrostatic steering, kick back free
 High safety and stability ensured by Linde ProtectorFrame
 Anti-glare display with fuel gauge, clock, hour meter and servicing information
 Control lights on display for engine oil pressure, engine overheating, parking brake, audible warning signal for engine and hydraulic oil temperature, blocked intake filter and low fuel level
 Plenty of storage space for writing utensils, beverage, cans...
 Air intake filter with integrated cyclone separator
 High-performance hydraulic filter concept, guarantees maximum oil purity and extends life of all hydraulic components

Optional Equipment

Single drive pedal with direction selector on armrest
 Overhead guard can be upgraded to full cabine with roof, front and rear screens and doors (also available with tinted glass)
 Wiper-washers for front, rear and roof screens
 Further seats with additional comfort and adjustments
 Cab heater with integrated pollen filter
 Air condition with integrated pollen filter
 Radio with speakers
 Sun screens, clipboard, interior lighting, height adjustable steering column
 Standard masts up to 5610 mm lift
 Duplex masts (full free lift) up to 4125 mm lift
 Triplex masts (full free lift) up to 6075 mm lift
 Integrated sideshift
 Integrated fork positioner
 Load backrest
 One or two auxiliary hydraulic circuits for all mast types
 Alternative fork lengths

LPG truck fitted with a two-way catalytic converter
 LPG truck fitted with accurate ultrasonic fuel level indicator for exchange bottles
 LPG volumetric fuel tank version has a fuel level indicator at the display
 Superelastic tyres

New STANDARD features for the Evo models:

New seat/armrest generation for outstanding ergonomics
 LEPS (Linde-Engine-Protection-System) as monitoring of the most important truck parameter
 Curve Assist for automatic speed adaption
 Intelligent drive dynamic modi now integrate lift hydraulic
 Enhanced steering axle
 Handhold for safe access at A-pillar
 Energy-efficient electric fan

Tilt cylinder- and roof protection
 Truck lighting, working lamps
 Audible reversing alarm, flasher and strobe beacons
 Mirrors
 Linde original Blue Spot
 Camera and colour monitor
 Road traffic specifications
 Integrated diesel particulate filter with charge status indicator on the display consul
 Air precleaner
 Water trap with audible warning
 Volumetric tank (LPG) with capacities of 36 l or 45 l
 3-way catalytic converter (LPG)
 Unregulated catalyst (Diesel)
 CNG (natural gas) version
 Linde Connected Solutions (Connect.)
 Custom paintwork

Other options available on request



Diesel, LPG and CNG Forklift Trucks
 Capacity 1400 - 2000 kg
 H14 EVO®, H16 EVO®,
 H18 EVO®, H20 EVO®

Series 391



Safety

Linde ProtectorFrame: The protective overhead guard and its supporting frame form together a strong protective zone providing optimum safety and protection for the operator. Top-mounted tilt cylinders provide seamless and smooth control of the tilt movements for excellent load stability in all operating conditions. This unique design also enables slimmer mast profiles to be fitted for outstanding visibility.

Performance

Low consumption and exhaust level and nevertheless this truck range continues to impress with its excellent performance. Advanced engine and drive technology combined with the original Linde Load Control system enables the operator to use the trucks vast potential to maximise productivity. Precise fingertip control of all mast functions.

Comfort

Step in relaxed, leave again relaxed. Linde brings to this forklift a generously sized automobile-class workspace. A perfect interface between operator and truck has been achieved with the Linde ergonomic design concept. The spacious cab, comfort-class seat with adjustable armrest and intuitive controls allow fast and stress-free working.

Reliability

Proven in tough applications. Decoupling of mast and drive axle with chassis and cabine results in reduced shock and vibration. The enclosed robot-welded chassis is designed for maximum strength and durability. The resilient, maintenance-free mountings of the axles and tilt jacks cut downtime and operating costs.

Productivity

50 years of permanent optimisation of the original Linde hydraulic system leads to effective and costefficient work: The original Linde hydrostatic transmission requires no differential, no drum brake, no gearshift and no clutch. As a result, uptime is optimised, productivity is increased and maintenance costs are low.

Features

Original Linde hydrostatic drive
 → Sensitive, smooth, and precise driving
 → No clutch, no differential, and no drum brakes thanks to Linde hydrostatic direct drive
 → Robust drive even in extreme environments

Linde twin drive pedals
 → Fast, smooth change of travel direction without constantly moving feet from one pedal to another
 → Short pedal stroke
 → No strain on ankles or legs
 → Operator maintains high efficiency levels



Linde operator's compartment
 → Advanced functional design for optimum operator comfort and efficiency
 → Superb working environment with spacious leg and headroom
 → Excellent visibility of load and surrounding environment through the slim-line mast sections
 → Resilient mounting of mast and drive axle absorbs road shocks and vibrations
 → Quiet, stress-free working

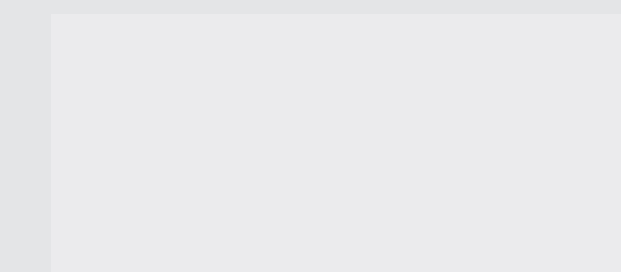

Linde Material Handling GmbH, Postfach 10 01 36, 63701 Aschaffenburg, Germany
 Phone +49.60 21.99-0, Fax +49.60 21.99-15 70, www.linde-mh.com, info@linde-mh.com

Linde ProtectorFrame
 → Enclosed, robot-welded chassis for maximum durability and protection of components
 → A hinged engine cover and removable service panels give wide, easy access for maintenance



Linde Load Control
 → Mini levers for all mast functions mounted on an adjustable armrest
 → Precise and effortless fingertip control of all mast functions for safe, efficient load handling
 → Engine rpm is automatically synchronised to precisely match hydraulic demands



Linde Truck Control (LTC)
 → Enables performance parameters to individual applications
 → Consistently high reliability due to dual circuits of all monitoring systems
 → Fully protected within sealed aluminium enclosure against ingress of dust or moisture
 → Automatic control of engine rpm to match hydraulic demand

High-economy engine technology
 → Modern, advanced technology Diesel, LPG and CNG engines
 → High torque for impressive and flexible performance
 → Extremely fuel efficient and exhaust emissions significantly below European limits



Linde clear-view mast
 → Superb visibility through the slim-profile mast sections
 → Full load capacity available up to maximum lift height
 → Excellent residual capacities
 → Maintenance-free resilient rubber mounting of mast/drive axle and tilt jacks
 → Electronic control of tilt angle
 → Electronic cushioning of end of travel for forward/back tilt



Subject to modification in the interest of progress. Illustrations and technical details could include options and not binding for actual constructions. All dimensions subject to usual tolerances.

Printed in Germany 084.c.3.10115.indd.k4

Technical Data according to VDI 2198

Characteristics	Linde Forklift Models											
	1.1	1.2	1.2a	1.3	1.4	1.5	1.6	1.8	1.9	2.1	2.2	2.3
1.1	Manufacturer	LINDE	LINDE	LINDE	LINDE	LINDE	LINDE	LINDE	LINDE	LINDE	LINDE	LINDE
1.2	Model designation	H14D	H16D	H18D	H20D	H14T	H16T	H18T	H20T	H20CG¹⁾		
1.2a	Series	391-00_EVO	391-00_EVO	391-00_EVO	391-00_EVO	391-00_EVO	391-00_EVO	391-00_EVO	391-00_EVO	391-00_EVO		
1.3	Power unit	Diesel	Diesel	Diesel	Diesel	LPG	LPG	LPG	LPG	CNG		
1.4	Operation	Seat	Seat	Seat	Seat	Seat	Seat	Seat	Seat	Seat		
1.5	Load capacity/Load	Q (t)	1.4	1.6	1.8	2.0	2.0	1.8	2.0	2.0		
1.6	Load centre	c (mm)	500	500	500	500	500	500	500	500		
1.8	Axle centre to fork face	x (mm)	365	365	370	374	365	365	374	374		
1.9	Wheelbase	y (mm)	1500	1500 (1600) ²⁾	1540 (1600) ²⁾	1600	1500	1500 (1600) ³⁾	1540 (1600) ³⁾	1600		
2.1	Service weight	(kg)	2585	2745 (2795) ²⁾	2915 (2910) ²⁾	3105	2565	2725 (2775) ³⁾	2895 (2890) ³⁾	3085		
2.2	Axle load with load, front/rear	(kg)	3487 / 498	3818 / 527 (3760 / 635) ²⁾	4157 / 558 (4119 / 591) ²⁾	4483 / 623	3447 / 518	3778 / 547 (3720 / 655) ³⁾	4117 / 578 (4079 / 611) ³⁾	4443 / 643		
2.3	Axle load without load, front/rear	(kg)	1280 / 1305	1295 / 1450 (1295 / 1500) ²⁾	1340 / 1575 (1340 / 1570) ²⁾	1390 / 1715	1240 / 1325	1255 / 1470 (1255 / 1520) ³⁾	1300 / 1595 (1300 / 1590) ³⁾	1350 / 1735		
3.1	Tyres rubber, SE, pneumatic, polyurethane		SE	SE	SE	SE	SE	SE	SE	SE		
3.2	Tyre size, front		180/70-8 (18x7-8)	180/70-8 (18x7-8)	180/70-8 (18x7-8)	200/50-10	180/70-8 (18x7-8)	180/70-8 (18x7-8)	180/70-8 (18x7-8)	200/50-10		
3.3	Tyre size, rear		180/70-8 (18x7-8)	180/70-8 (18x7-8)	180/70-8 (18x7-8)	180/70-8 (18x7-8)	180/70-8 (18x7-8)	180/70-8 (18x7-8)	180/70-8 (18x7-8)	180/70-8 (18x7-8)		
3.5	Wheels, number front/rear (x = driven)		2x / 2	2x / 2	2x / 2	2x / 2	2x / 2	2x / 2	2x / 2	2x / 2		
3.6	Track width, front	b10 (mm)	930	930	930	945	930	930	930	945		
3.7	Track width, rear	b11 (mm)	873	873	873	873	873	873	873	873		
4.1	Mast/fork carriage tilt, forward/backward	a/b (°)	6.0 / 9.0 ⁴⁾	6.0 / 9.0 ⁴⁾	6.0 / 9.0 ⁴⁾	6.0 / 9.0 ⁴⁾	6.0 / 9.0 ⁴⁾	6.0 / 9.0 ⁴⁾	6.0 / 9.0 ⁴⁾	6.0 / 9.0 ⁴⁾		
4.2	Height of mast, lowered	h1 (mm)	2197 ³⁾	2197 ³⁾	2197 ³⁾	2198 ³⁾	2197 ³⁾	2197 ³⁾	2197 ³⁾	2198 ³⁾		
4.3	Free lift	h2 (mm)	150	150	150	150	150	150	150	150		
4.4	Lift	h3 (mm)	3150	3150	3150	3150	3150	3150	3150	3150		
4.5	Height of mast, extended	h4 (mm)	3754	3754	3754	3755	3754	3754	3754	3755		
4.7	Height of overhead guard (cabin)	h6 (mm)	2123	2123	2123	2123	2123	2123	2123	2123		
4.8	Height of seat/stand on platform	h7 (mm)	1067	1067	1067	1067	1067	1067	1067	1067		
4.12	Towing coupling height	h10 (mm)	557	557 (530) ²⁾	549 (530) ²⁾	530	557	557 (530) ³⁾	549 (530) ³⁾	530		
4.19	Overall length	l1 (mm)	3112	3112 (3222) ²⁾	3152 (3222) ²⁾	3231	3112	3152 (3222) ³⁾	3152 (3222) ³⁾	3231		
4.20	Length to fork face	l2 (mm)	2212	2212 (2322) ²⁾	2252 (2327) ²⁾	2331	2212	2252 (2322) ³⁾	2252 (2322) ³⁾	2331		
4.21	Overall width	b1/b2 (mm)	1086	1086	1086	1152	1086	1086	1086	1152		
4.22	Fork dimensions	s/e/l (mm)	40 x 80 x 900	40 x 80 x 900	45 x 100 x 900	45 x 100 x 900	40 x 80 x 900	40 x 80 x 900	45 x 100 x 900	45 x 100 x 900		
4.23	Fork carriage to ISO 2328, class/type A, B		2A	2A	2A	2A	2A	2A	2A	2A		
4.24	Width of fork carriage	b3 (mm)	980	980	980	980	980	980	980	980		
4.31	Ground clearance, below mast	m1 (mm)	94	93 (95) ²⁾	92 (95) ²⁾	95	94	93 (95) ³⁾	92 (95) ³⁾	95		
4.32	Ground clearance, centre of wheelbase	m2 (mm)	120	119 (121) ²⁾	118 (121) ²⁾	121	120	119 (121) ³⁾	118 (121) ³⁾	121		
4.33	Aisle width with pallet 1000 x 1200 across forks	Ast (mm)	3570 ⁴⁾	3570 (3686) ²⁾⁴⁾	3611 (3691) ²⁾⁴⁾	3695 ⁴⁾	3570 ⁴⁾	3570 (3686) ³⁾⁴⁾	3611 (3691) ³⁾⁴⁾	3695 ⁴⁾		
4.34	Aisle width with pallet 800 x 1200 along forks	Ast (mm)	3770 ⁴⁾	3770 (3886) ²⁾⁴⁾	3811 (3891) ²⁾⁴⁾	3895 ⁴⁾	3770 ⁴⁾	3770 (3886) ³⁾⁴⁾	3811 (3891) ³⁾⁴⁾	3895 ⁴⁾		
4.35	Turning radius	Wa (mm)	2005	2005 (2121) ²⁾	2041 (2121) ²⁾	2121	2005	2005 (2121) ³⁾	2041 (2121) ³⁾	2121		
4.36	Minimum pivoting point distance	b13 (mm)	600	600 (638)	600 (638)	638	600	600 (638)	600 (638)	638		
5.1	Travel speed, with/without load	(km/h)	20 / 20	20 / 20	20 / 20	20 / 20	20 / 20	20 / 20	20 / 20	20 / 20		
5.2	Lifting speed, with/without load	(m/s)	0.6 / 0.63	0.6 / 0.63	0.6 / 0.63	0.54 / 0.57	0.6 / 0.63	0.6 / 0.63	0.6 / 0.63	0.54 / 0.57		
5.3	Lowering speed, with/without load	(m/s)	0.57 / 0.57	0.57 / 0.57	0.57 / 0.57	0.57 / 0.57	0.57 / 0.57	0.57 / 0.57	0.57 / 0.57	0.57 / 0.57		
5.5	Tractive force, with/without load	(N)	12900 / 9800	12900 / 9900	12900 / 10300	12900 / 10700	12900 / 9500	12900 / 9600	12900 / 10000	12900 / 10400		
5.7	Climbing ability, with/without load	(%)	35.0 / 39.0	32.0 / 37.0	35.0 / 38.0	29.0 / 36.0	35.0 / 35.0	27.0 / 35.0	27.0 / 35.0	27.0 / 35.0		
5.9	Acceleration time, with/without load	(s)	4.7 / 4.2	4.9 / 4.3	5.0 / 4.5	5.1 / 4.6	4.7 / 4.2	4.9 / 4.3	5.0 / 4.5	5.1 / 4.6		
5.10	Service brake		hydrostatic	hydrostatic	hydrostatic	hydrostatic	hydrostatic	hydrostatic	hydrostatic	hydrostatic		
7.1	Engine manufacturer/type		VW BXT	VW BXT	VW BXT	VW BXT	VW BEF	VW BEF	VW BEF	VW CBS		
7.2	Engine performance according to ISO 1585	(kW)	26	26	26	26	28	28	28	30		
7.3	Rated speed	(1/min)	2100	2100	2100	2100	2100	2100	2100	2100		
7.4	Number of cylinders/displacement	(-/cm3)	4 / 1896	4 / 1896	4 / 1896	4 / 1896	4 / 1984	4 / 1984	4 / 1984	4 / 1984		
7.5	Fuel consumption according to VDI cycle	(l/h)	2.1	2.2	2.3	2.4	-	-	-	-		
7.5a	Fuel consumption according to VDI cycle	(kg/h)	-	-	-	-	1.9	2	2.1	2.2		
7.5b	Fuel consumption according to VDI cycle	(m3/h)	-	-	-	-	-	-	-	-		3.2 (H); 3.5 (L) ⁷⁾
8.1	Type of drive control		hydrost./stepl.	hydrost./stepl.	hydrost./stepl.	hydrost./stepl.	hydrost./stepl.	hydrost./stepl.	hydrost./stepl.	hydrost./stepl.		
8.2	Operating pressure for attachments	(bar)	180	170	170	170	180	170	170	170		
8.3	Oil flow for attachments	(l/min)	38	38	38	38	38	38	38	38		
8.4	Noise level at operator's ear	(dB(A))	75	75	75	75	73	73	73	73		
8.5	Towing coupling, design/type, DIN 15 170		-	-	-	-	-	-	-	-		

1) Technical specifications for H16/H18 on request
 2) Values in parenthesis when ordering ETB particulate filter (Filter Changing)
 3) Values in parenthesis when ordering LPG bottles (big) for GB, AUS, J
 4) Lift height and equipment can alter rear mast tilt angle

5) With 150 mm free lift
 6) Including a 200 mm (min.) operating aisle clearance.
 7) (H)= high quality, (L)= low quality

Load Capacity Diagrams

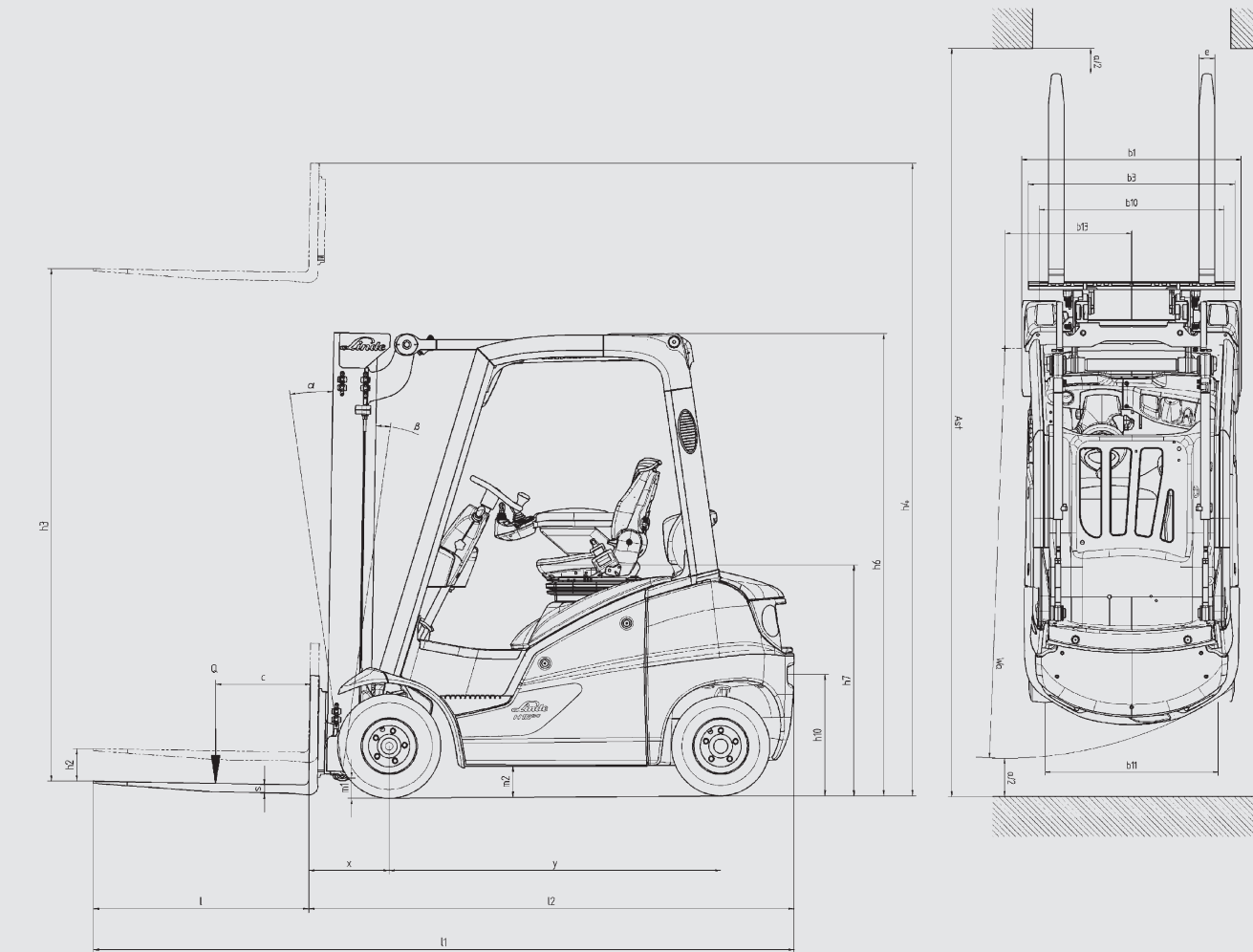
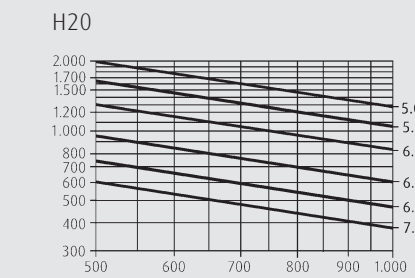
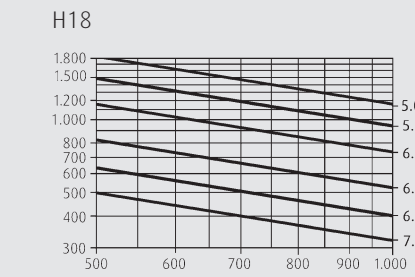
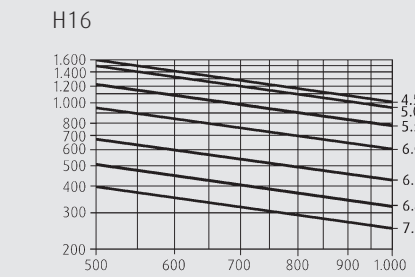
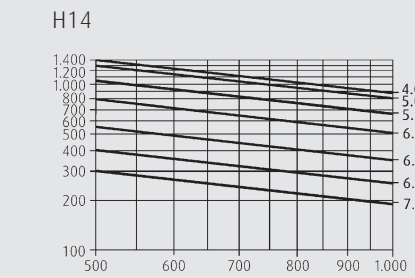

Overall height and lift heights, Standard (in mm)		H14/H16/H18/H20		
Lift	h3	3150	3850	4250
Mast retracted (with 150 mm free lift - standard)	h1#	2196	2546	2746
Mast extended	h4	3713	4413	4813
Special free lift	h2	150	150	150
Overall height and lift heights, Duplex (in mm)		H14/H16/H18/H20		
Lift	h3	3145	3845	-
Mast retracted	h1	2121	2471	-
Mast extended	h4	3727	4427	-
Special free lift	h2	1518	1868	-
Overall height and lift heights, Triplex (in mm)		H14/H16/H18/H20		
Lift	h3	4625	5475	-
Mast retracted	h1	2121	2471	-
Mast extended	h4	5227	6077	-
Special free lift	h2	1518	1781	-

Figures for other equipments and triplex masts on request